

# ***EDC Series***

*HIGH EFFICIENCY DOUBLE CONVERSION UPS WITH POWER CONDITIONER*

## **USER'S GUIDE**

EDC1500RT-T

EDC2200RT-T

EDC2200RT-THW



**SMART POWER SYSTEMS**

800-882-8285 | [supportcenter@emergepowersolutions.com](mailto:supportcenter@emergepowersolutions.com)  
7409 Railhead Ln. Houston, Texas 77086

## IMPORTANT SAFETY INSTRUCTIONS

This manual contains important instructions. Please read and follow all instructions carefully during installation and operation of the unit. Read this manual thoroughly before attempting to unpack, install, or operate the UPS.

**CAUTION!** The UPS must be connected to a grounded AC power outlet with fuse or circuit breaker protection. DO NOT plug the UPS into an outlet that is not grounded. If you need to power-drain this equipment, turn off and unplug the unit.

**CAUTION!** The battery can power hazardous components inside the unit, even when the AC input power is disconnected.

**CAUTION!** The UPS should be placed near the connected equipment and easily accessible.

**CAUTION!** To prevent the risk of fire or electric shock, install in a temperature and humidity controlled indoor area, free of conductive contaminants. (Please see specifications for acceptable temperature and humidity range).

**CAUTION! (No User Serviceable Parts):** Risk of electric shock, do not remove cover. No user serviceable parts inside. Refer servicing to qualified service personnel.

**CAUTION! (Non-Isolated Battery Supply):** Risk of electric shock, battery circuit is not isolated from AC power source; hazardous voltage may exist between battery terminals and ground. Test before touching.

**CAUTION!** To reduce the risk of fire, connect the UPS to a branch circuit with 20amperes (EDC2200RT) maximum over-current protection in accordance to ANSI/NFPA 70 requirement.

**CAUTION!** The AC outlet where the UPS is connected should be close to the unit and easily accessible.

**CAUTION!** Please use only UL-tested, UL-marked mains cable, (e.g. the mains cable of your equipment), to connect the UPS to the AC outlet.

**CAUTION!** Please use only UL-tested, UL-marked power cables to connect any equipment to the UPS.

**CAUTION!** When installing the equipment, ensure that the sum of the leakage current of the UPS and the connected equipment does not exceed 3.5mA.

**CAUTION!** The EDC2200RT Battery module models are only qualified maintenance personnel may carry out installations.

**CAUTION!** Do not unplug the unit from AC Power during operation, as this will invalidate the protective ground insulation.

**CAUTION!** To avoid electric shock, turn off and unplug the unit before installing the input/output power cord with a ground wire. Connect the ground wire prior to connecting the line wires!

**CAUTION!** Do not use an improper size power cord as it may cause damage to your equipment and cause fire hazards.

**CAUTION!** Wiring must be done by qualified personnel.

**CAUTION! DO NOT USE FOR MEDICAL OR LIFE SUPPORT EQUIPMENT!** Under no circumstances this unit should be used for medical applications involving life support equipment and/or patient care.

**CAUTION! DO NOT USE WITH OR NEAR AQUARIUMS!** To reduce the risk of fire, do not use with or near aquariums. Condensation from the aquarium can come in contact with metal electrical contacts and cause the machine to short out.

**CAUTION!** Do not dispose of batteries in fire as the battery may explode.

**CAUTION!** Do not open or mutilate the battery, released electrolyte is harmful to the skin and eyes.

**CAUTION!** A battery can present a risk of electric shock and high short circuit current. The following precaution should be observed when working on batteries

1. Remove watches, rings or other metal objects.
2. Use tools with insulated handles.
3. Wear rubber gloves and boots.
4. Do not lay tools or metal parts on top of batteries.
5. Disconnect charging source and load prior to installing or maintaining the battery.
6. Remove battery grounds during installation and maintenance to reduce likelihood of shock. Remove the connection from ground if any part of the battery is determined to be grounded.

**CAUTION!** The unit has a dangerous amount of voltage. When the UPS indicators is on, the units may continue to supply power thus the unit's outlets may have a dangerous amount of voltage even when it's not plugged in to the wall outlet.

**CAUTION!** Make sure everything is turned off and disconnected completely before conducting any maintenance, repairs or shipment.

**CAUTION!** Connect the Protection Earth (PE) safety conductor before any other cables are connected.

**CAUTION! (Fuses):** To reduce the risk of fire, replace only with the same type and rating of fuse.

**CAUTION!** When replacing batteries, replace with the same type and number of batteries or battery packs.

**DO NOT INSTALL THE UPS WHERE IT WOULD BE EXPOSED TO DIRECT SUNLIGHT OR NEAR A STRONG HEAT SOURCE!**

**DO NOT BLOCK OFF VENTILATION OPENINGS AROUND THE HOUSING!**

**DO NOT CONNECT DOMESTIC APPLIANCES SUCH AS HAIR DRYERS TO UPS OUTPUT SOCKETS!**

**SERVICING OF BATTERIES SHOULD BE PERFORMED OR SUPERVISED BY PERSONNEL KNOWLEDGE OF BATTERIES AND THE REQUIRED PRECAUTIONS. KEEP UNAUTHORIZED PERSONNEL AWAY FROM BATTERIES!**

## IMPORTANT SAFETY INSTRUCTIONS

Ce manuel contient des instructions importantes. Veuillez lire et suivre attentivement toutes les instructions lors de l'installation et de l'utilisation de l'appareil. Lisez ce manuel entièrement avant de tenter de déballer, installer ou utiliser l'UPS.

**ATTENTION!** L'UPS doit être connecté à une prise de courant CA mise à la terre équipée d'un fusible ou d'un disjoncteur de protection. **NE PAS** brancher l'UPS dans une prise non mise à la terre. Si vous avez besoin de décharger cette équipement, éteignez-le et débranchez-le.

**ATTENTION!** La batterie peut alimenter des composants dangereux à l'intérieur de l'appareil, même lorsque l'alimentation CA est déconnectée.

**ATTENTION!** L'UPS doit être placé près de l'équipement connecté et facilement accessible.

**ATTENTION!** Pour éviter tout risque d'incendie ou de choc électrique, installez-le dans un endroit intérieur à température et humidité contrôlées, exempt de contaminants conducteurs. (Veuillez consulter les spécifications pour connaître la plage de température et d'humidité acceptables).

**ATTENTION!** (Aucune pièce réparable par l'utilisateur) : Risque de choc électrique, ne pas enlever le couvercle. Aucune pièce réparable par l'utilisateur à l'intérieur. Confiez l'entretien à du personnel qualifié.

**ATTENTION!** (Alimentation de batterie non isolée) : Risque de choc électrique, le circuit de la batterie n'est pas isolé de la source d'alimentation CA ; une tension dangereuse peut exister entre les bornes de la batterie et la terre. Testez avant de toucher.

**ATTENTION!** Pour réduire le risque d'incendie, connectez l'UPS à un circuit de dérivation avec une protection contre les surintensités maximale de 20 ampères (EDC2200RT) conformément aux exigences de l'ANSI/NFPA 70.

**ATTENTION!** La prise CA à laquelle l'UPS est connecté doit être proche de l'appareil et facilement accessible.

**ATTENTION!** Utilisez uniquement un câble secteur testé et marqué UL (par exemple, le câble secteur de votre équipement) pour connecter l'UPS à la prise CA.

**ATTENTION!** Utilisez uniquement des câbles d'alimentation testés et marqués UL pour connecter tout équipement à l'UPS.

**ATTENTION!** Lors de l'installation de l'équipement, assurez-vous que la somme du courant de fuite de l'UPS et de l'équipement connecté ne dépasse pas 3,5 mA.

**ATTENTION!** Seul du personnel de maintenance qualifié peut installer les modèles de modules de batterie EDC2200RT

**ATTENTION!** Ne débranchez pas l'appareil de l'alimentation CA pendant le fonctionnement, car cela invalidera l'isolation de la terre de protection.

**ATTENTION!** Pour éviter tout choc électrique, éteignez et débranchez l'appareil avant d'installer le cordon d'alimentation d'entrée/sortie avec un fil de terre. Connectez le fil de terre avant de connecter les fils de ligne !

**ATTENTION!** N'utilisez pas un cordon d'alimentation de taille inappropriée, car cela pourrait endommager votre équipement et présenter un risque d'incendie.

**ATTENTION!** Le câblage doit être effectué par du personnel qualifié.

**ATTENTION!** NE PAS UTILISER POUR DES ÉQUIPEMENTS MÉDICAUX OU DE SUPPORT DE VIE ! En aucun cas, cet appareil ne doit être utilisé pour des applications médicales

impliquant des équipements de support de vie et/ou des soins aux patients.

**ATTENTION! NE PAS UTILISER AVEC OU PRÈS D'AQUARIUMS!** Pour réduire le risque d'incendie, ne pas utiliser avec ou près d'aquariums. La condensation de l'aquarium peut entrer en contact avec les contacts électriques métalliques et provoquer un court-circuit de la machine.

**ATTENTION!** Ne pas jeter les batteries au feu, car elles risquent d'exploser.

**ATTENTION!** Ne pas ouvrir ou mutiler la batterie, l'électrolyte libéré est nocif pour la peau et les yeux.

**ATTENTION!** Une batterie peut présenter un risque de choc électrique et un fort courant de court-circuit. Les précautions suivantes doivent être observées lors du travail sur les batteries :

1. Retirez les montres, bagues ou autres objets métalliques.
2. Utilisez des outils avec des poignées isolées.
3. Portez des gants et des bottes en caoutchouc.
4. Ne posez pas d'outils ou de pièces métalliques sur les batteries.
5. Déconnectez la source de charge et la charge avant d'installer ou d'entretenir la batterie.

6. Retirez les masses des batteries pendant l'installation et l'entretien pour réduire le risque de choc électrique. Si une partie quelconque de la batterie est déterminée comme étant mise à la terre, retirez la connexion à la terre.

**ATTENTION!** L'appareil présente une tension dangereuse. Lorsque les indicateurs de l'UPS sont allumés, l'appareil peut continuer à fournir de l'énergie, de sorte que les prises de l'appareil peuvent présenter une tension dangereuse même lorsqu'il n'est pas branché à la prise murale.

**ATTENTION!** Assurez-vous que tout est éteint et complètement déconnecté avant de procéder à tout entretien, réparation ou expédition.

**ATTENTION!** Connectez le conducteur de sécurité de terre de protection (PE) avant tout autre câble.

**ATTENTION!** (Fusibles) : Pour réduire le risque d'incendie, remplacez uniquement par un fusible du même type et de même valeur.

**ATTENTION!** Lors du remplacement des batteries, utilisez des batteries ou des packs de batteries du même type et du même nombre.

**NE PAS INSTALLER L'UPS DANS UN ENDROIT OÙ IL SERA EXPOSÉ À LA LUMIÈRE SOLAIRE DIRECTE OU PRÈS D'UNE SOURCE DE CHALEUR ÉLEVÉE!**

**NE PAS BLOQUER LES OUVERTURES DE VENTILATION AUTOUR DU BOÎTIER!**

**NE PAS CONNECTER DES APPAREILS DOMESTIQUES TELS QUE DES SÈCHES-CHEVEUX AUX PRISES DE SORTIE DE L'UPS!**

**L'ENTRETIEN DES BATTERIES DOIT ÊTRE EFFECTUÉ OU SURVEILLÉ PAR DU PERSONNEL AYANT CONNAISSANCE DES BATTERIES ET DES PRÉCAUTIONS NÉCESSAIRES. ÉCARTEZ LE PERSONNEL NON AUTORISÉ DES BATTERIES!**

## UNPACKING

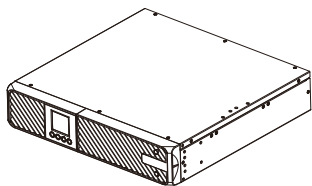

UPS



User's manual



Input power cord  
(5-15P+C13 for 1.5KVA)  
(5-20P+C19 for 2.2KVA)



Rack mount Flat head screws: M4X8L (8)



Rack mount Pan head screws: M5X12L (4)



Rack mount Plastic washers (4)



Rack mount Screw hole dust covers (8)

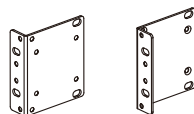

Rack mount ears (Stands) (2)

# INSTALLATION

## HARDWARE INSTALLATION

These versatile UPS systems can be mounted in a rack mount or vertical tower orientation. This versatility is especially important to growing organizations with changing needs that value having the option to position a UPS on a floor or in a rack mount system. Please follow the instructions below for the respective mounting methods.

## SAFETY PRECAUTIONS

**CAUTION!** To prevent the risk of fire or electric shock, only use the supplied hardware to attach the mounting brackets.

## RACKMOUNT INSTALLATION

### Step 1: Rack mount ears installation

Attach the two rack mount ears to the UPS using the provided screws M4X8L\*8pcs.

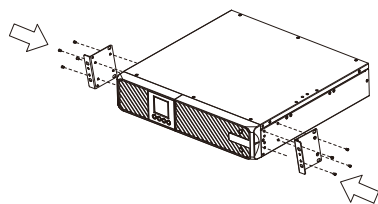

### Step 2: Rack mount rails Installation

1) The rails adjust to mount in 48-cm (19-inch) panel racks from 52 to 91.5cm (20.5 to 36 inches) deep. Select the proper holes in the rack for positioning the UPS in the rack. The UPS takes up position 1 through position 6.

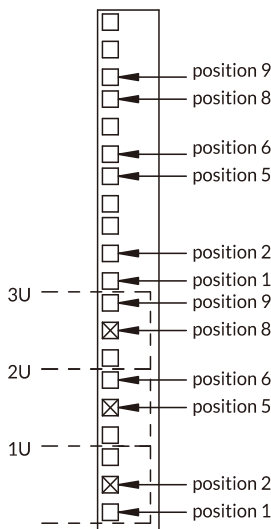

2) Attach the rack mount rail to your rack with two M5X12L screws and two plastic washers at the front of the rack. (Located in position 1 & position 6) Do not tighten the screws. Adjust the rail size on the rail assembly of your rack. Secure the rail to the rear of the rack with two M5X12L screws and two plastic washers. Tighten all screws at the front and rear of the rail. Once completed, perform the same steps for assembling the other rack mount rail.

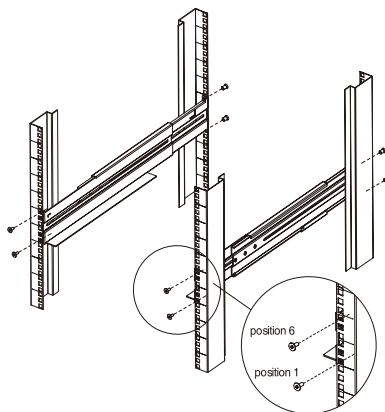

### Step 3: Install the UPS on the rack

Place the UPS on a flat stable surface with the front of the unit facing toward you. Secure the UPS to your rack with four M5X12L screws at the front of the rack. (Located in position 2 & position 5).

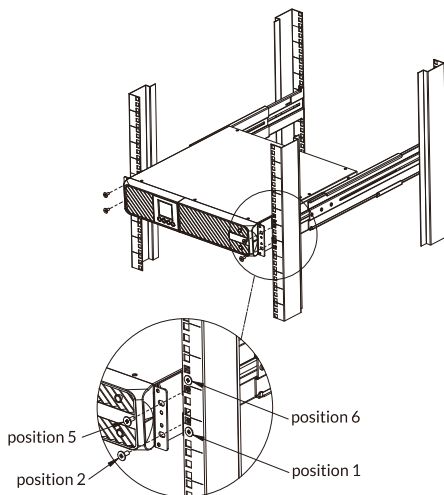

# INSTALLATION

## VERTICAL/TOWER INSTALLATION

### Step 1: Attach the base stands

Tighten the screws (M4X8\*8pcs) of the base stands (rack mount ears) onto the bottom of the UPS.

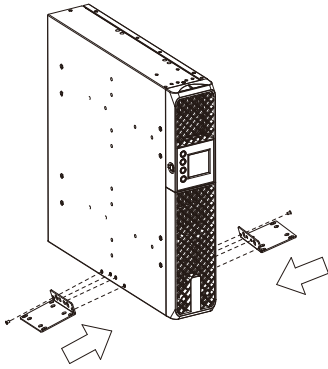

### Step 2: Attach dust covers

Insert dust cover into the rack mount ear screw holes that are not being used.

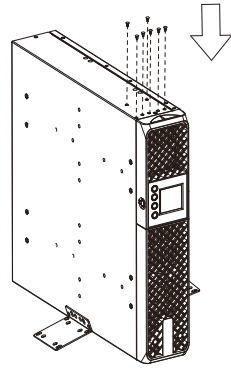

## Battery installation and replacement

**Step 1:** Remove the front panel. Remove the retaining screws from the battery bracket and then remove the cover itself. Disconnect the connectors.

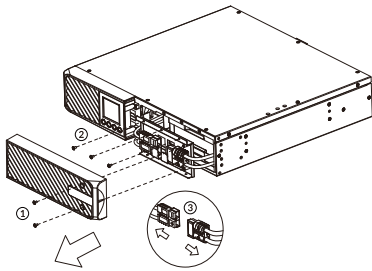

**Step 3:** Fasten the battery bracket and then insert the connectors. Place the connectors in the bracket.

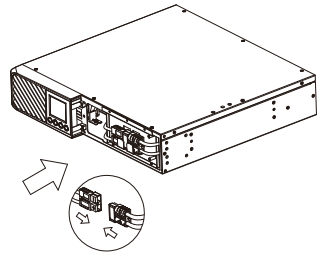

**Step 2:** Pull the battery tray out slowly. Put the new battery tray back into the compartment after that.

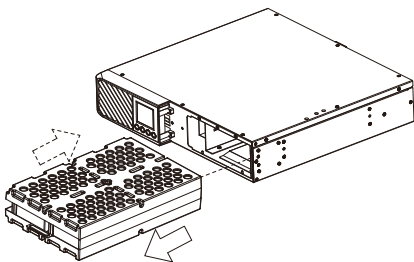

**Step 4:** Tighten the screws of the battery bracket and front panel.

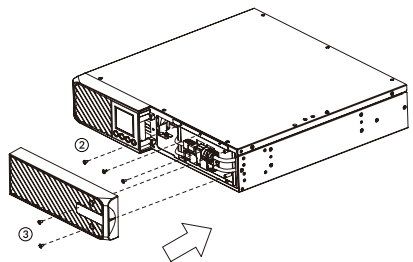

# INSTALLATION

## ELECTRICAL INSTALLATION

After completing the hardware installation of the UPS, you are now ready to plug in the UPS and connect your equipment.

## SOFTWARE INSTALLATION

Power Master+ management software provides a user-friendly interface for your power systems. The graphic user-interface is intuitive and displays essential power information at a glance. Please follow procedure below to install the software.

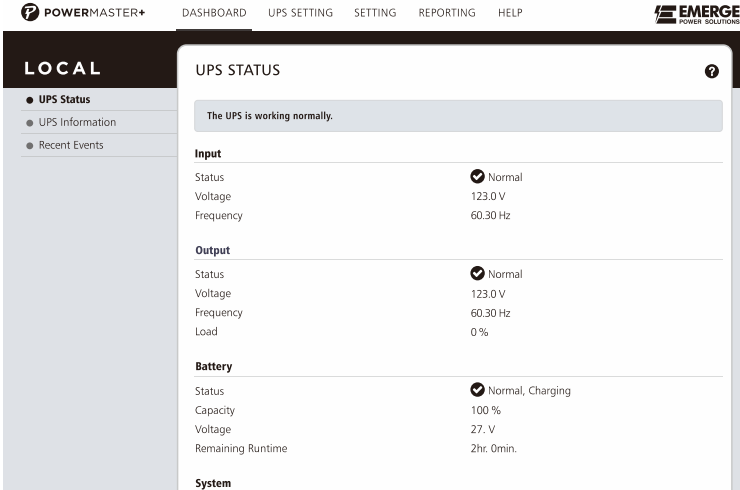

**POWERMASTER+** DASHBOARD UPS SETTING SETTING REPORTING HELP **EMERGE** POWER SOLUTIONS

### LOCAL

- UPS Status
- UPS Information
- Recent Events

### UPS STATUS

The UPS is working normally.

Input	
Status	Normal
Voltage	123.0 V
Frequency	60.30 Hz

Output	
Status	Normal
Voltage	123.0 V
Frequency	60.30 Hz
Load	0 %

Battery	
Status	Normal, Charging
Capacity	100 %
Voltage	27. V
Remaining Runtime	2hr. 0min.

**System**

### Installation procedure:

1. Download Power Master+ from the website:

<https://emergepowersolutions.com/downloads/Smartpowermaster/pm106-setup.zip>

2. Double-click the file and follow the installation steps. When your computer restarts, the Power Master+ software will appear as a blue icon located in the system tray.

## SAFETY PRECAUTIONS

**CAUTION!** Installation environment should be in a temperature and humidity controlled indoor area free of conductive contaminants. Do not install this UPS where excessive moisture or heat is present (Please see specifications for acceptable temperature and humidity range).

**ATTENTION!** L'environnement d'installation doit être un espace intérieur avec régulation de la température et de l'humidité, exempt de contaminants conducteurs. Ne pas installer cet onduleur (UPS) dans un endroit exposé à une humidité ou une chaleur excessives (veuillez consulter les spécifications pour connaître la plage acceptable de température et d'humidité).

**CAUTION!** Never install a UPS, or associated wiring or equipment, during a lightning storm.

**ATTENTION!** Ne jamais installer un onduleur (UPS), ni les câblages ou équipements associés, pendant une tempête avec éclairs.

**CAUTION!** Do not work alone under hazardous conditions.

**ATTENTION!** Ne pas travailler seul dans des conditions dangereuses.

**CAUTION!** In case of the risk of electric shock, do not remove the top cover.

**ATTENTION!** En cas de risque de choc électrique, ne pas enlever le couvercle supérieur.

**CAUTION!** The battery can energize hazardous live parts inside even when the AC input power is disconnected.

**ATTENTION!** La batterie peut alimenter des composants sous tension dangereux à l'intérieur, même lorsque l'alimentation électrique alternative (AC) est déconnectée.

# INSTALLING YOUR UPS SYSTEM

## SYSTEM BLOCK DIAGRAM

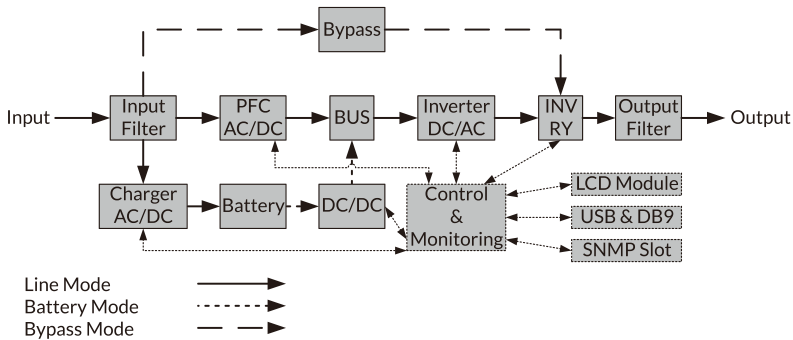

## HARDWARE INSTALLATION GUIDE

1. Battery charge loss may occur during shipping and storage. Before using the UPS, it's strongly recommended to charge batteries for four hours to ensure the batteries' maximum charge capacity. To recharge the batteries, simply plug the UPS into an AC outlet.

2. When using the included software, connect either the serial or the USB cable between the computer and the corresponding port on the UPS. Note: If the USB port is used, the serial port will be disabled. They cannot be used simultaneously.

3. Connect your computer, monitor, and any externally-powered data storage device (Hard drive, Tape drive, etc.) into the outlets only when the UPS is off and unplugged. DO NOT plug a laser printer, copier, space heater, vacuum, paper shredder or other large electrical device into the UPS. The power demands of these devices will overload and possibly damage the unit.

4. Press the ON switch to turn the UPS on. If an overload is detected, an audible alarm will sound and the UPS will continuously emit one beep per second. For resetting the unit, unplug some equipment from the outlets. Make sure your equipment carries a load current within the unit's safe range, (refer to the technical specifications).

5. This UPS is equipped with an auto-charge feature. When the UPS is plugged into an AC outlet, the battery will automatically charge, even when the unit is switched off.

6. To maintain an optimal battery charge, leave the UPS plugged into an AC outlet at all times.

7. Before storing the UPS for an extended period of time, turn the unit OFF. Then cover it and store it with the batteries fully charged. Recharge the batteries every three months to ensure good battery capacity and long battery life. Maintaining a good battery charge will help prevent possible damage to the unit from battery leakage.

8. The UPS has one USB port (default) and one Serial port that allows connection and communication between the UPS and any attached computer running the Power Master software. The UPS can control the computer's shutdown during a power outage through the connection while the computer can monitor the UPS and alter various programmable parameters. Note: Only one communication can be used at a time. The port not in use will automatically become disabled or the serial port will be disabled if both ports are attached.

9. EPO (Emergency Power Off) /ROO (Remote on/off) Port: EPO/ROO ports allow administrators the capability to connect the UPS unit to customer-supplied EPO/ROO switches. If EPO is enabled, these installations give operators a single access point to immediately power-off all equipment connected to the UPS during an emergency. If ROO is enabled, these installations give operators a access point to turn on/off UPS remotely.

10. To avoid electric shock, turn the unit OFF and disconnect the unit from utility power before hardwiring the UPS (in/out power cord). The in/out power cord **MUST** be grounded.

## BASIC OPERATION

### POWER MODULE FRONT/REAR PANEL DESCRIPTION

#### 1. Power On/Off Button

Master ON/OFF for the UPS.

#### 2. Function Buttons

Scroll up, scroll down, select and cancel LCD menu.

#### 3. Multifunction LCD Readout

Indicate status information, settings and events.

#### 4. Input Circuit Breaker

Provide input overload and fault protection.

#### 5. Battery Backup & Surge Protected Outlets

All outlets provide surge protection and power conditioning as well as battery backup during the power outage. On models EDC1500RT-T and EDC2200RT-T, the top 4-way outlets are Always On for critical loads, and the bottom 4-way outlets are switchable / controllable.

#### 6. Serial Port

Serial port provides communication between the UPS and the computer. The UPS can control the computer's shutdown during a power outage through the connection while the computer can monitor the UPS and alter its various programmable parameters.

#### 7. USB port

This is a connectivity port which allows communication and control between the UPS and the connected computer. It is recommended to install the Power Master+ software on the PC/Server connected with the USB cord.

#### 8. SNMP/HTTP Network slot

Slot to install the optional SNMP card for remote network control and monitoring.

#### 9. EPO (Emergency Power Off) Connector

Enable Power-Off in emergency from a remote location.

#### 10. AC Input Inlet

Connect the AC Power cord to a properly wired and grounded outlet or output terminal block.

#### 11. Extended Runtime Battery Module Connector

Connection for additional battery modules. Maximum of three battery packs allowed.

#### 12. RJ45/11 Communication Protection Ports

Communication protection ports will protect any standard modem, fax, telephone line, or network cable.

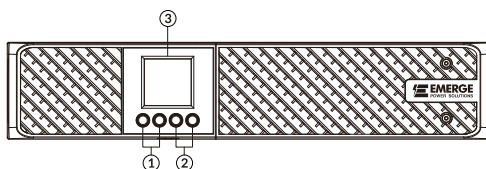

**EDC1500RT / EDC2200RT**

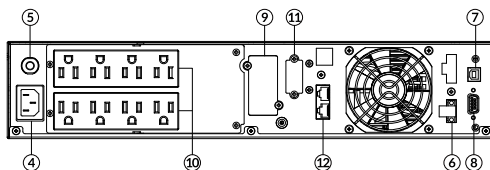

**EDC1500RT**

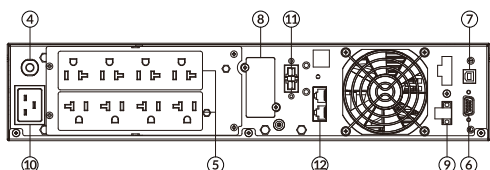

**EDC2200RT-T**

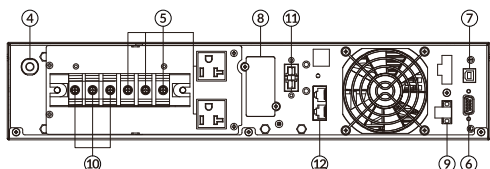

**EDC2200RT-THW**

### BATTERY MODULE FRONT/REAR PANEL DESCRIPTION

#### 1. On-board Replaceable Fuse Cover

Replaceable fuse is accessible from the rear panel. It must be done by qualified personnel.

#### 2. Input Connector

Use this input Connector to connect the Battery module to the Power module or to the next Battery module.

#### 3. Output Connector

Use this output connector to daisy chain the next Battery module. Remove the connector cover for access.

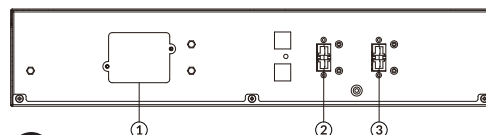
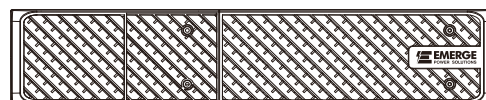

**BP-EDC2200RT-EBM**

## BASIC OPERATION

### CONNECTION 1: POWER MODULE WITH ONE BATTERY MODULE

Use the battery cable of the Battery module to connect the Battery module to the Power module.

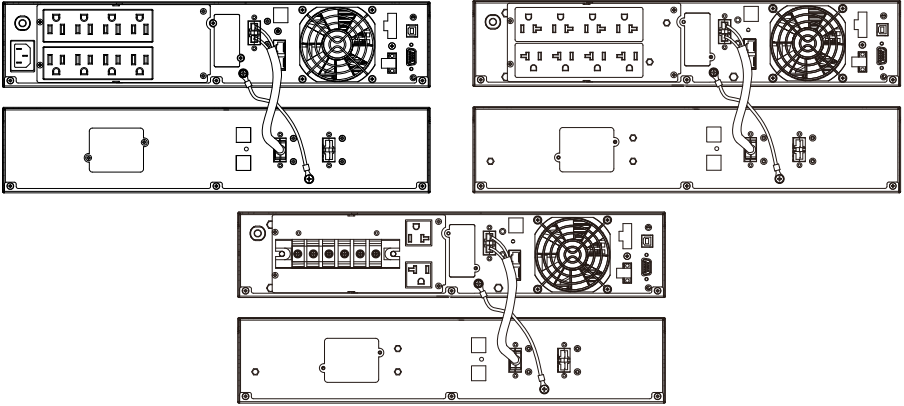

EDC2200RT-T / EDC2200RT-THW

### CONNECTION 2: POWER MODULE WITH MULTIPLE BATTERY MODULES

Step1: Connect the first Battery module to the Power module via battery cable.

Step2: Use the battery cable to connect the second Battery module to the first Battery module.

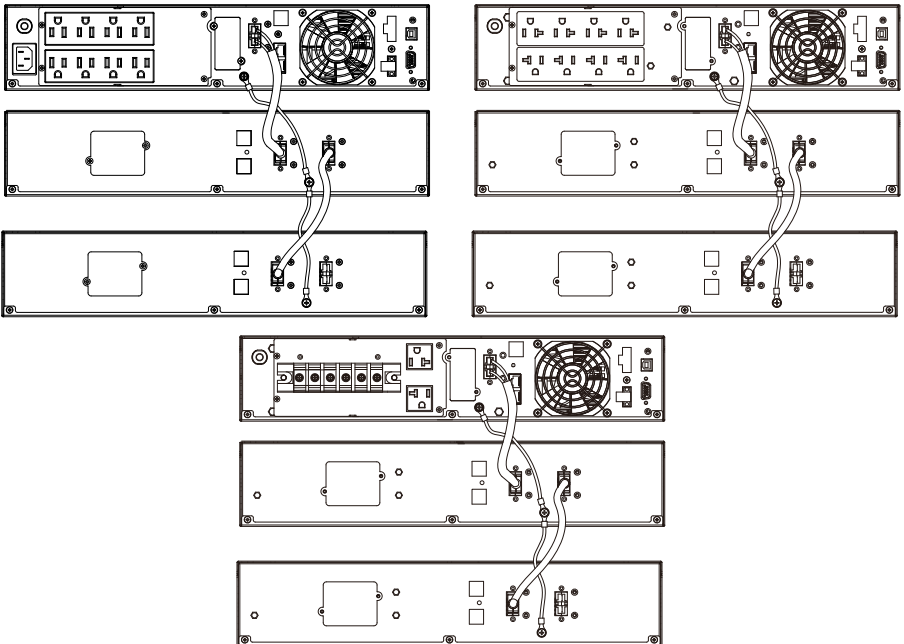







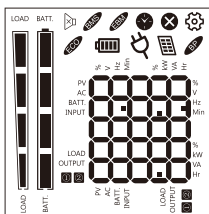

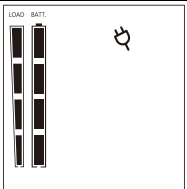
EDC2200RT-T / EDC2200RT-THW

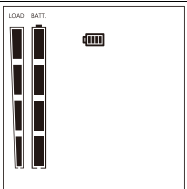
# BASIC OPERATION

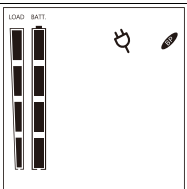
## LCD PANEL

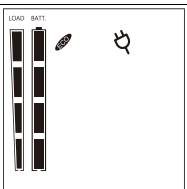

LCD SCREEN – ICON DESCRIPTION		
UPS MODE	MODE DESCRIPTION	UPS TOPOLOGY : MODE DISPLAY
Line Mode  	UPS is operating in Line Mode. The UPS is operating and protecting the equipment normally.	
Battery Mode  	UPS is operating in Battery Mode. A utility power failure has occurred. The UPS is using battery power to work and protect the equipment.	
Bypass Mode  	UPS is operating in Bypass Mode. A Warning or fault has been detected and the UPS transfers output to utility power.	
ECO Mode  	UPS is operating in ECO (Economy) Mode. If Bypass quality is within the ECO mode setting specifications, the UPS will operate in Bypass until input power is disqualified per set specifications. At that time the UPS will automatically switch to Line Mode.	
UPS STATUS	STATUS DESCRIPTION	
Fault (Warning)  	A Warning or fault has been detected and the UPS transfers output to utility power.	
Mute  	The audible alarm is disabled.	

## BASIC OPERATION

### BUTTON OPERATION

Button	OPERATION DESCRIPTION
<b>ON</b>	Press this button to turn on UPS. In line mode, ECO mode, or converter mode, press the "ON" button for 5 seconds to activate the battery test.
<b>OFF</b>	Press this button to turn off UPS.
<b>ENTER</b>	Press and hold this button for 5 seconds to get into setting mode while in bypass mode, or standby mode. In setting mode, press this button to confirm selection, or press this button for longtime to exit setting mode and saving changes. Press this button to scroll up in the LCD menu.
<b>ESC</b>	In setting mode, press this button to display next selection, or press this button for long time to exit setting mode without saving changes. Press and hold the "ESC" button for 5 seconds to disable and enable buzzer alarm. Press this button to scroll down in the LCD menu.
<b>ENTER+ESC</b>	Switch to bypass mode: When the main power is normal, press these two buttons simultaneously for 5 seconds, then UPS will enter to bypass mode.
<b>ON+ENTER</b>	Rotate the LCD display: if user want to change LCD to tower display, press these two buttons simultaneously for 5 seconds

### STATUS

There are 6 types of UPS status Readout available for display. Press the "UP"(ENTER) and "DOWN" (ESC) buttons to scroll items shown in the table below.

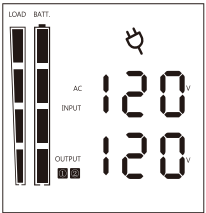
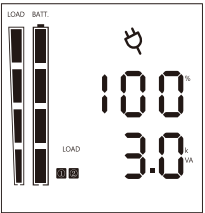
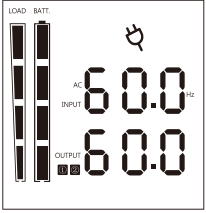
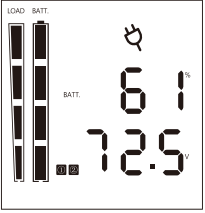
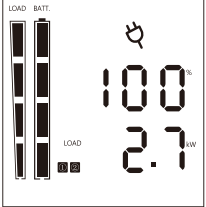
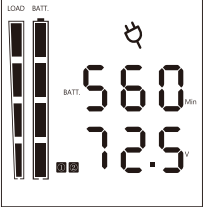
1	INPUT (Voltage) V  OUTPUT (Voltage) V		4	VA Load Percentage (%)  OUTPUT XXX VA	
2	INPUT (Frequency) HZ  OUTPUT (Frequency) HZ		5	Battery Capacity Percentage (%)  Battery Voltage (V)	
3	W Load Percentage (%)  OUTPUT XXX W		6	Backup Time (min) Percentage (%)  Battery Voltage (V)	

## BASIC OPERATION

### Setup - There are 10 UPS items that can be Set Up by the user.

1. Press and hold the "ENTER" button for 5 seconds to activate the setting mode. The first configuration parameter will be displayed on the LCD screen.

Note: The manual settings programming mode can ONLY be invoked while UPS is in Bypass mode or Standby mode. To make UPS on Standby mode or Bypass mode, connect utility power to UPS and do not turn on UPS.

2. Press the "ENTER" button to select the setting you want to configure.
3. Press the "ESC" buttons to scroll through the different parameters and select the parameter you want.
4. Press the "ESC" button for 5 seconds to cancel and exit setting mode. Press the "ENTER" button for 5 seconds to save all the settings you just do and exit setting mode.

Setting Item	Configure Submenu	Available Settings	Default Setting
001	Output Voltage	[100V] [110V] [115V] [120V] [127V]	120V
002	Output Frequency	[50Hz] [60Hz]	60Hz
003	ECO Mode	[0%] (Disable) [10%][15%] (Enable)	0%
004	Bypass Mode	[DIS] (Disable) [ENA] (Enable)	Enable
005	Converter Mode	[DIS] (Disable) [ENA] (Enable)	Disable
006	Site Fault	[DIS] (Disable) [ENA] (Enable)	Disable
007	Bypass when UPS is Off	[FlD] (Disable) [FlE] (Enable)	Disable
008	Outlet Group	[DIS] (Disable) [ENA] (Enable)	Enable
009	Battery Self Test	[BST](Battery Self Test) [10S](Test 10S) [LOW] (Test till battery low)	Test 10s
010	Battery Monthly Test	[DIS] (Disable) [ENA] (Enable)	Enable

\*) When operating in ECO Mode, the efficiency of UPS is higher than that in online mode, but transfer time should not be 0ms.

\*\*) When operating in Converter Mode, the frequency of output should be always 50Hz or 60Hz, but load capacity will be derated by 45%.

\*) This function would be set as 0% when Converter Mode is enabled.

\*\*) UPS has no bypass when Converter Mode is enabled.

### Event Code List

Event ID	Description of Cause
01	<b>Bus Start Fail:</b> DC-DC converter or bus sensing circuit failed.
02	<b>Bus Volt High:</b> DC-DC converter failed.
03	<b>Bus Volt Low:</b> DC-DC converter failed.
04	<b>Bus Unbalanced:</b> DC-DC converter failed.
06	<b>INV Start Fail:</b> Inverter circuit failed.
07	<b>INV Volt High:</b> Inverter circuit or output voltage sensing circuit failed.
08	<b>INV Volt Low:</b> The load may be too heavy or inverter circuit failed.
09	<b>INV Short:</b> The inverter circuit failed.
11	<b>Bat Volt High:</b> The external battery module connection is wrong, or the charger failed.
12	<b>Bat Volt Low:</b> Batteries failed.
14	<b>Over Load:</b> UPS is overloaded.
18	<b>Fan Fail:</b> The ventilation hole has been covered, or the fans can't work.
19	<b>Over Temperature:</b> High ambient temperature, or the ventilation hole has been covered.
56	<b>Bat Volt Low:</b> Battery voltage is low.
57	<b>Bat Cap Low:</b> Battery capacity is low.
59	<b>Bat disconnect:</b> Battery is disconnected.
60	<b>Overcharge:</b> Charger voltage is high.
61	<b>Charger fail:</b> Charger is failed.
62	<b>Bat Volt Low Or BatCap Low:</b> Battery voltage is low, or Battery capacity is low.
64	<b>Over Load warning:</b> UPS is overloaded.
66	<b>EPO Off:</b> Missing the EPO connection
68	<b>Over Temperature:</b> High ambient temperature, or the ventilation hole has been covered. This is shown only when start up UPS.
69	<b>Fan Lock:</b> Fans can't work because of lock.

## MAINTENANCE

### Storage

To store your UPS for an extended period, cover it and store with the battery fully charged. Recharge the battery every three months to ensure battery life.

### Safety Precautions

**CAUTION!** Only use replacement batteries which are certified by Supplier Systems. Use of incorrect battery type is an electrical hazard that could lead to explosion, fire, electric shock, or short circuit.

**ATTENTION!** N'utilisez que des batteries de remplacement certifiées par Supplier Systems. L'utilisation d'un type de batterie incorrect constitue un risque électrique pouvant entraîner une explosion, un incendie, un choc électrique ou un court-circuit.

**CAUTION!** Batteries contain an electrical charge that can cause severe burns. Before servicing batteries, please remove any conductive materials such as jewelry, chains, wrist watches, and rings.

**ATTENTION!** Les batteries contiennent une charge électrique susceptible de causer des brûlures graves. Avant d'effectuer des interventions sur les batteries, retirez tous les objets conducteurs tels que bijoux, chaînes, montres et bagues.

**CAUTION!** Do not open or mutilate the batteries. Electrolyte fluid is harmful to the skin/eyes and may be toxic.

**ATTENTION!** Ne pas ouvrir ni mutiler les batteries. Le liquide électrolytique est nocif pour la peau et les yeux et peut être toxique.

**CAUTION!** To avoid electric shock, turn off and unplug the UPS from the wall receptacle before servicing the battery.

**ATTENTION!** Pour éviter tout choc électrique, éteignez l'onduleur (UPS) et débranchez-le de la prise murale avant d'effectuer des interventions sur la batterie.

**CAUTION!** Only use tools with insulated handles. Do not lay tools or metal parts on top of the UPS or battery terminals.

**ATTENTION!** N'utilisez que des outils à poignées isolées. Ne posez pas d'outils ou de pièces métalliques sur l'onduleur (UPS) ou les bornes de la batterie.

### Replacement Batteries

Please refer to the front side of the UPS for the model number of the correct replacement batteries. For battery procurement, contact your local dealer.

### Battery Disposal

Batteries are considered hazardous waste and must be disposed of properly. Contact your local government for more information about proper disposal and recycling of batteries. Do not dispose of batteries in fire.

## TECHNICAL SPECIFICATIONS

		EDC1500RT-T	EDC2200RT-T/EDC2200RT-THW
Capacity (VA -Watt)		1500VA - 1350W	2200VA - 1800W
Energy -saving Technology		Yes, ECO Mode Efficiency $\cong$ 95%	
<b>Input</b>			
Input Voltage Range		120 Vac	
Input Frequency Range		50/60Hz	
Input Power Factor		0.99	
Cold Start		Yes	
UPS Inlets		IEC C14	IEC C20 /HARD WIRE TERMINAL
<b>Output</b>			
Output Waveform		Pure Sine Wave	
Default Output Voltage		120Vac	
Supported Output Voltage (s)		100V; 110V; 115V; 120V; 127V	
Output Frequency		50/60Hz ( Auto -Sensing or Configurable ) $\pm$ 0.5Hz **	
Line Mode Voltage Regulation		$\pm$ 1%,	
ECO Mode Voltage Regulation		$\pm$ 10%, $\pm$ 15% ( Configurable )	
Crest Factor		3:1	
Harmonic Distortion		THD < 3% at Linear Load, THD < 6% at Non -linear Load	
UPS Outlets		(8) NEMA 5-15R	(8) NEMA 5-20R (4) Remote switchable set) / Terminal+(2) NEMA 5-20R
Transfer Time (Typically)		0ms	
<b>Battery</b>			
Model – Voltage		EP015 - 36VDC (Sealed, Maintenance Free)	EP022 - 48VDC (Sealed, Maintenance Free)
Run Time ( Half Load )		12 Minutes	
Recharge Time (Typically)		4 Hours (inside batteries)	
<b>Protection</b>			
Power Conditioning		Protection against Common Mode, Normal Mode, Ground Loop Interferences	
Overload Protection	Line mode	105%~110% Warning, transfer to bypass after 10min; 110%~130% Warning, transfer to bypass after 1min; >130% Warning, transfer to bypass after 3s.	
	Battery Mode	105%~110% Warning, shut down after 6min; 110%~130% Warning, shut down after 1min; >130% Warning, shut down after 3s.	
	Bypass mode	110%~120% Warning, shut down after 30min ; 120%~130% Warning, shut down after 10min; >130% Warning, shut down after 1min.	
Short Circuit Protection		UPS Output Cut off Immediately or Input Fuse / Circuit Breaker Protection	
<b>Management</b>			
LCD Screen		Graphic LCD	
Connectivity Ports		(1) Serial Port (RS232), (1) USB Port	
Emergency Power Off (EPO)		Yes	
Audible Alarms		Battery Mode, Battery Low, Overload, UPS Fault, Replace Battery, Bypass Mode Charger Failure / Over Charged, Fan failure, EPO active	
Power Management Software		Power Master+	
SNMP/HTTP Capable		(1) Expansion Port (With optional card)	
<b>Environment</b>			
Operating Temperature		0°C to 49°C	
Operating Relative Humidity		20% to 90% Non - Condensing	
<b>Physical</b>			
Dimensions (W x H x D) (mm.)		438 x 88 x 430	
Net Weight (kg)		15.40	18.25
Altitude		<2000m	

\*\*\*) Within 50/60Hz $\pm$ 8% by default, the output frequency is synchronization with input mains. User can adjust the acceptable range for output frequency ( $\pm$ 1, 2, 3, 4, 5, 6, 7, 8, 9, 10%). When input frequency is out of synchronization window but within 40-70Hz, UPS can stay in line mode and output frequency is regulated at 50/60Hz $\pm$ 0.5% with load derating by 40%.

## TROUBLE SHOOTING

Problem	Possible Cause	Solution
<b>Warning</b>		
O/P Overload	Your equipment requires more power than the UPS can provide. If the UPS is in Line Mode then it will transfer to Bypass Mode; if the UPS is in Battery Mode it will shut down.	Shut off non-essential equipment. If this solves the overload problem, the UPS will transfer to normal operation.
Battery Mode	UPS is operating on battery power.	Save your data and perform a controlled-shutdown.
Battery Low	UPS is operating on battery power and will be shutting down soon due to extremely low battery voltage.	UPS will restart automatically when acceptable utility power returns.
BAT Disconnected/ Battery Replace	Missing battery power.	Check battery connector when use battery packages.
	UPS has failed in Battery Test.	Contact technical support to replace the battery.
Charger Failure	Charger has failed.	<ol style="list-style-type: none"> <li>1. Shut down UPS and turn off AC input.</li> <li>2. Contact Supplier for repair.</li> </ol>
EPO OFF	Missing the EPO connection.	Check the EPO connection.
<b>Fault</b>		
Over Temperature	High ambient temperature.	<ol style="list-style-type: none"> <li>1. Shut down UPS . Restart UPS to Check the fan for operation and if the ventilation hole has been covered .</li> <li>2. Contact Supplier for repair.</li> </ol>
Output Short	Output short circuit.	<ol style="list-style-type: none"> <li>1. Shut down UPS.</li> <li>2. Your attached equipment may have problems, please remove them and check again.</li> </ol>
High O/P V	Output voltage is too high.	<ol style="list-style-type: none"> <li>1. Shut down UPS.</li> <li>2. Contact Supplier for repair.</li> </ol>
Low O/P V	Output voltage is too low.	
Bus Fault	Internal DC bus voltage is too high or too low.	
<b>Other</b>		
Startup fail	High temperature , or fan fail, orbattery low, or EPO off.	<ol style="list-style-type: none"> <li>1. Restart UPS and press the "DOWN" button to view the warning event. Then refer to the solution for the warning.</li> <li>2. Contact Supplier for repair.</li> </ol>

All rights reserved. Reproduction without permission is prohibited.



800-882-8285 | [supportcenter@emergepowersolutions.com](mailto:supportcenter@emergepowersolutions.com)

K01-C001097-00